

Nozzle selection guide

Sb – pinpoint gating, versatile tip that can be positioned right into the gate area. Suitable for most materials: PP, PS, PE, PA6, ABS, SAN, POM, PC & PPE.

SbH – pinpoint gating, similar to Sb but with extra hard steel sleeve inside tip for abrasive materials. Suitable for all materials as per Sb plus abrasives.

SG – open flow tip with replaceable hard steel sleeve. Suitable for large and technical parts, good flow: PMMA, PC, ABS/PC, PSU, PBT, & Glassfibre Plastics.

SGL – open flow tip transferring heat to the gate area for crystalline plastics. Suitable for materials: ABS/PC, PMMA, PS, & Glassfibre Plastics.

SS – retro hot sprue nozzle, directly contacts mould cavity, replaces cold sprues. Suitable for most materials as for Sb.

SSL – longer retro hot sprue nozzle for modifying to suit cavity shape. Suitable most materials as for Sb.

MICRO – pinpoint, smallest MASTIP™ for multi cavity use in small parts including medical parts

and floppy discs. Suitable for materials: PP, PE, PS, ABS, & SAN.

32 SIZE – large 12.5mm diameter bore nozzles available in Sb, SbH, SG, SGL, SS, & SSL tip styles to suit parts up to 3kg, available in lengths up to 250mm.

SV – valve gate system for use with SG and SGL nozzles on parts and materials that require positive gate closure or thicker wall parts. Suitable for most materials including technical plastics.

TEMPERATURE

CONTROLLERS – MASTIP™ fully automatic controllers offer optimum control of plastic temperature to within 1°, assists part quality, single or multi-zone systems available, all use Type J (FeCuNi) thermocouples.

MANIFOLDS – a full range of standard manifolds and accessories, available in 3 shapes: Parallel, Cross and 'H' pattern, using ceramic spacers to reduce heat transfer. Special fully balanced manifolds are made to request using full CAE flow analysis.

NOZZLE SELECTION GUIDE

L=Low viscosity	PP, PS, PE
M=Medium viscosity	ABS, POM, SAN, PA6, PUR
H=High viscosity	PSO, PPE, PMMA, PPS, PBT, ABS
G=Glass reinforced	GF PC, PETP, PPO, PSO, PA6.6(GF)

Model	Shot weight (grams)			
	L	M	H	G
MASPOINT™ (Sb & SbH) (SbH only *)				
1245/75	30	25	20	10*
1636/56/86	100	80	60	50*
1946/66/96/60	500	250	150	100*
2286/116/146	1000	700	450	350*
32 Series	2500	2000	1500	1000

MASFLOW™ (SG & SGL)				
1636/56/86	120	90	50	30
1946/66/96/60	500	300	200	100
2286/116/146	1100	800	450	400
32 Series	2800	2000	1500	1000

MASPRUE™ (SS & SSL)				
1636/56/86	110	70	60	–
1946/66/96/60	400	200	130	–
2286/116/146	900	600	300	–
32 Series	2500	2000	1500	–

Based on gate sizes of 1.5mm except for SS and 32 Series.

These are recommendations only and based on average cycle times. For high speed moulding the next size up nozzle may be required to cope with the grams per shot required.

MAPOINT™

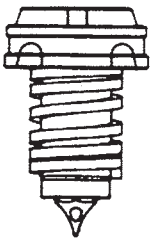

Sb/SbH Series
Pin Point gating

MASFLOW™



SG/SGL Series
Open Flow Tip/Steel Sleeve

MASPRUE™

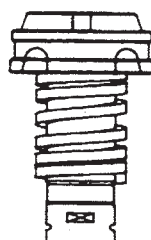

SS/SSL Series
Retro Fit

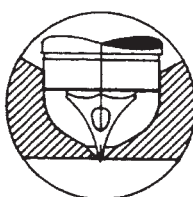
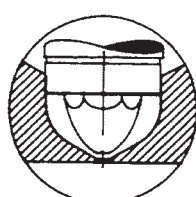
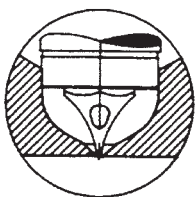

Please note that great care is taken to ensure the information in this catalogue is correct at the time of printing. MASTIP™ reserves the right, however, to change specifications as required.

MASPOINT™ Sb pinpoint gating

- **Single or Multi-cavity use**
- **Full length CuBe core and tip**
- **Excellent heat profile**
- **Interchangeable tip styles**

The Sb Series is a versatile nozzle extensively used on most materials for pinpoint gating. This latest third generation design features a hardened nickel plated *full length Copper Beryllium* core which provides an *even heat profile* throughout the nozzle – essential to *prevent burning plastic materials*.

Its unique insulated tip area can be positioned very close to the product inside the gate area: *maintaining the melt temperature, eliminating contact with plastic parts and replacing sprues feeding into runner systems.*

The reliable high watt square coil heater can be connected with most standard temperature controllers that use 'J' type (FeCuNi) thermocouples.

Features:

- Replaceable tips
- 10 model lengths
- Single cavity or multi-cavity application
- Adjustable gate size and nozzle position
- No expansion ring on parts
- Interchangeable with other tip styles, eg. SbH, SG & SGL

Options:

- Hard tip (SbH version, 60 HRC) for *glass filled materials*
- Special tips for *frequent colour changes*
- Cast heaters for *longer life*
- Teflon tip to *eliminate plastic insulation for frequent colour changes*

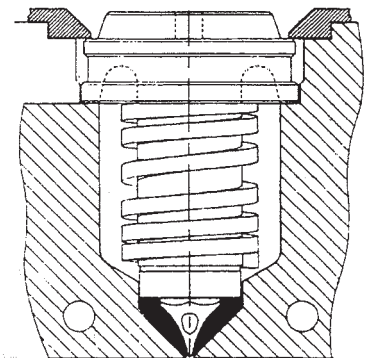
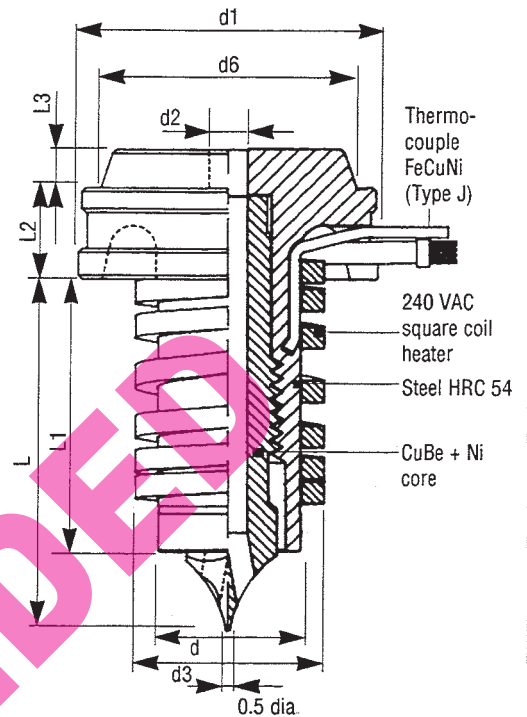

SEE FITTING INSTRUCTIONS FOR FURTHER GATE DETAILS AND SIZES

Supplied with O Ring Groove added. R 1/2 on R 3/4 will take it out. (see below)

Thermocouple – FeCuNi (Type J)
All heaters are square coil 240 VAC.
Cast heaters are available on request.
Pack includes: body & tip assembly, square coil heater and thermocouple with 1,000mm steel braid cables.

Model	d	L	d1	d2	d3	d6	L1	L2	L3	Watts heater
All dimensions in mm.										
Sb 1636	16	36	30	5	22	25	26	10	5	250
Sb 1656	16	56	30	5	22	25	46	10	5	325
Sb 1686	16	86	30	5	22	25	76	10	5	470
Sb 1946	19	46	40	6	25	35	36	12	5	325
Sb 1966	19	66	40	6	25	35	56	12	5	470
Sb 1996	19	96	40	6	25	35	86	12	5	630
Sb 1960	19	59.5	54.5	6	25	49	41	15.5	12.5	470
Sb 2286	22	86	50	8	28	45	76	15.5	12.5	630
Sb 22116	22	116	50	8	28	45	106	15.5	12.5	630
Sb 22146	22	146	50	8	28	45	136	15.5	12.5	630

OPTIONS

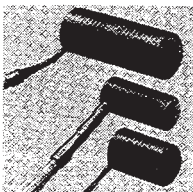

CAST HEATERS on request. To order add 'CH', eg. Sb1966CH

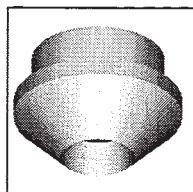

INSULATION CAP to eliminate plastic insulation. To order add 'TT', eg. Sb1966TT

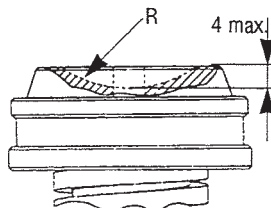

RADIUS MODIFICATION for single cavity use

O-Ring groove

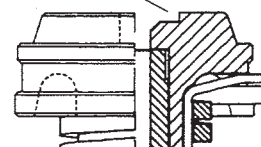

O-RING MODIFICATION for multi-cavity use

MASPOINT™ SbH - hard steel tip - pinpoint gating

The SbH has a hard steel (60HRC) tip which is interchangeable with the standard Sb nozzle range - it fits exactly in the Sb nozzle body.

The SbH Series expands the versatility of the Sb nozzles to include abrasive and glass reinforced materials. Its unique insulated tip area can be positioned very close to the product inside the gate area resulting in *minimum mark on plastic parts* and *replacing sprues feeding into runner systems*.

The reliable high watt square coil heater can be connected with most standard temperature controllers that use 'J' type (FeCuNi) thermocouples.

Features:

- Suitable for *abrasive materials, glass reinforced plastics*
- Ideal for *long production runs* requiring very fine tips
- *Hard steel tip interchangeable* with other tip styles incl. Sb, SG, SGL

Options:

- Special tips for *frequent colour changes*
- Cast heaters for *longer life*
- Teflon tip to eliminate plastic insulation for frequent colour changes

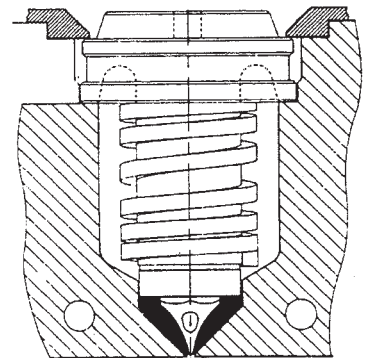
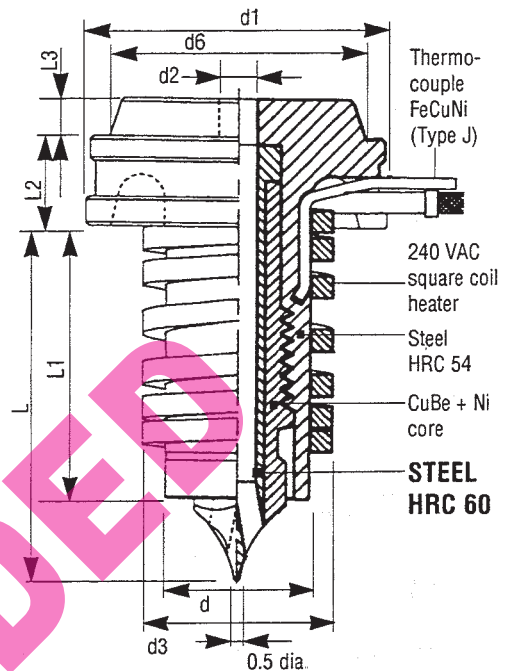

SEE FITTING INSTRUCTIONS FOR FURTHER GATE DETAILS AND SIZES

Model	d	L	d1	d2	d3	d6	L1	L2	L3	Watts heater
All dimensions in mm.										
SbH 1636	16	36	30	4	22	25	26	10	5	250
SbH 1656	16	56	30	4	22	25	46	10	5	325
SbH 1686	16	86	30	4	22	25	76	10	5	470
SbH 1946	19	46	40	5	25	35	36	12	5	325
SbH 1966	19	66	40	5	25	35	56	12	5	470
SbH 1996	19	96	40	5	25	35	86	12	5	630
SbH 1960	19	59.5	54.5	5	25	49	41	15.5	12.5	470
SbH 2286	22	86	50	7	28	45	76	15.5	12.5	630
SbH 22116	22	116	50	7	28	45	106	15.5	12.5	630
SbH 22146	22	146	50	7	28	45	136	15.5	12.5	630

Supplied with O Ring Groove added.
R 1/2 on R 3/4 will take it out. (see below)

Thermocouple - FeCuNi (Type J)

All heaters are square coil 240 VAC.

Cast heaters are available on request.

Pack includes: body & tip assembly, square coil heater and thermocouple with 1,000mm steel braid cables.

OPTIONS

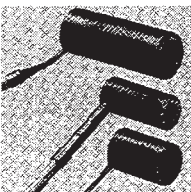

CAST HEATERS on request. To order add 'CH', eg. SbH1966CH

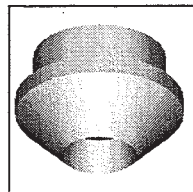

INSULATION CAP to eliminate plastic insulation. To order add 'TT', eg SbH1966TT

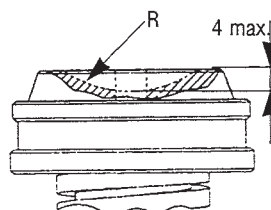

RADIUS MODIFICATION for single cavity use

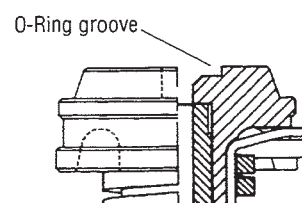

O-RING MODIFICATION for multi-cavity use

MASFLOW™ SG open gating

- Full length BeCu core and tip
- Excellent heat profile
- Interchangeable with similar nozzles

The MASFLOW™ SG Series is similar in function to the MASPOINT™ Sb except that it has a cleaner open material channel through one hole in the tip.

The full length Beryllium Copper tip contains a replaceable hardened steel (HRC 60) sleeve inside the CuBe core. This makes the MASFLOW™ Series suitable for most materials including Glass Reinforced Technical Plastics.

The reliable high watt square coil heater can be connected with most standard temperature controllers that use 'J' type (FeCuNi) thermocouples.

Features:

- Open material flow
- Suitable most materials
- Ideal glass filled or abrasive plastics
- Suitable larger parts
- Can be used with plastic insulation or air insulation around tip by adjusting nozzle position

Options:

- SGL model – steel inner tip protrudes through to cavity face – plastic tip insulation becomes an air gap
- Cast heaters for longer life
- Teflon tip to eliminate plastic insulation for frequent colour changes

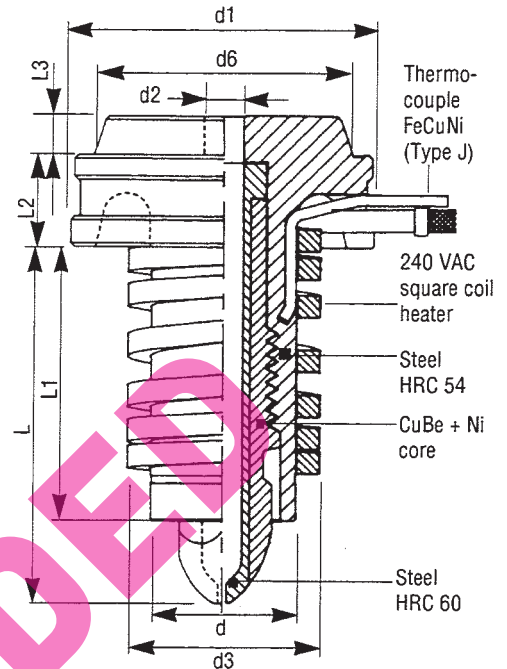

SEE FITTING INSTRUCTIONS FOR FURTHER GATE DETAILS AND SIZES

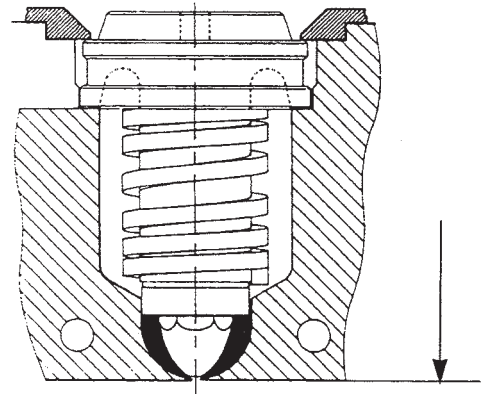

Nozzle can be adjusted forward to contact back of cavity. Eliminates plastic insulation, ideal for materials such as PMMA and Flame Retardants.
OR use teflon bush (TT)

Model	d	L	d1	d2	d3	d6	L1	L2	L3	Watts heater
All dimensions in mm.										
SG 1636	16	36	30	4	22	25	26	10	5	250
SG 1656	16	56	30	4	22	25	46	10	5	325
SG 1686	16	86	30	4	22	25	76	10	5	470
SG 1946	19	46	40	5	25	35	36	12	5	325
SG 1966	19	66	40	5	25	35	56	12	5	470
SG 1996	19	96	40	5	25	35	86	12	5	630
SG 1960	19	59.5	54.5	5	25	49	41	15.5	12.5	470
SG 2286	22	86	50	7	28	45	76	15.5	12.5	630
SG 22116	22	116	50	7	28	45	106	15.5	12.5	630
SG 22146	22	146	50	7	28	45	136	15.5	12.5	630

Supplied with O Ring Groove added.
R 1/2 on R 3/4 will take it out. (see below)

Thermocouple – FeCuNi (Type J)
All heaters are square coil 240 VAC.
Cast heaters are available on request.
Pack includes: body & tip assembly, square coil heater and thermocouple with 1,000mm steel braid cables.

OPTIONS

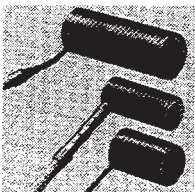

CAST HEATERS on request. To order add 'CH', eg. SG1966CH

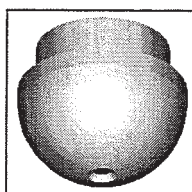

INSULATION CAP to eliminate plastic insulation. To order add 'TT', eg. SG1966TT

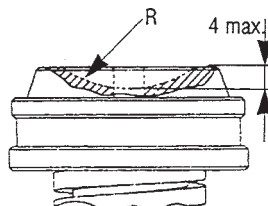

RADIUS MODIFICATION for single cavity use

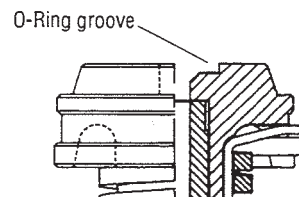

O-RING MODIFICATION for multi-cavity use

MASFLOW™ SGL

- No plastic insulation at tip
- Ideal for technical plastics
- Full length BeCu core and tip
- Excellent heat profile
- Interchangeable with similar nozzles

The MASFLOW™ SGL Series is designed for technical plastics, difficult materials including those that are glass fibre reinforced. The extra hard (HRC 60) steel inner tip protrudes through to the cavity face, eliminating the plastic insulation around the tip usual with the MASFLOW™ SG. An air gap exists around the tip.

The MASFLOW™ SGL exploits the same clean open material channel through one hole in the tip.

The full length Copper Beryllium tip contains a replaceable hardened steel (HRC 60) sleeve inside the CuBe core. This makes the MASFLOW™ series suitable for most materials including Glass Reinforced Technical Plastics.

The reliable high watt square coil heater can be connected with most standard temperature

controllers that use 'J' type (FeCuNi) thermocouples.

Features:

- Ideal for engineering plastics and flame retardants
- Ideal for glassfibre reinforced materials
- Ideal for materials which degrade when held for long especially in insulation areas of tip

Options:

- SG model - features plastic insulation around the nozzle tip

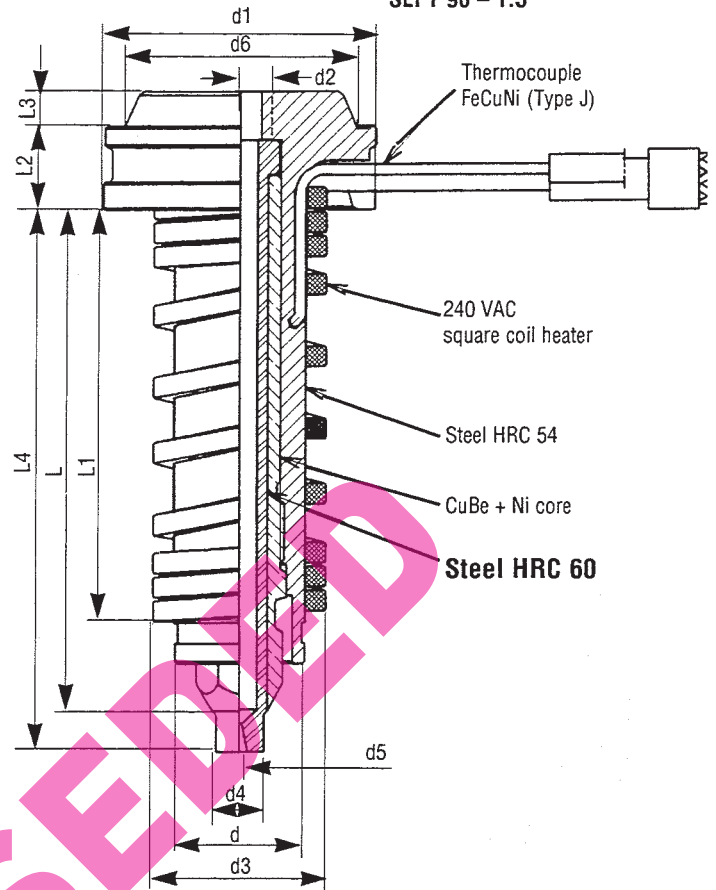

SEE FITTING INSTRUCTIONS FOR FURTHER GATE DETAILS AND SIZES

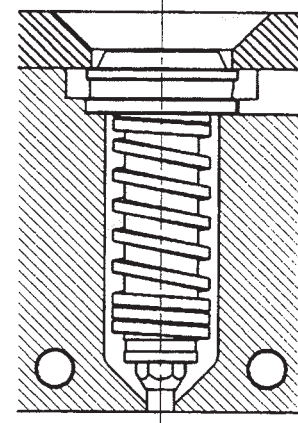

INSULATION AIR GAP

Supplied with O Ring Groove added. R 1/2 on R 3/4 will take it out. (see below)

Thermocouple - FeCuNi (Type J)
All heaters are square coil 240 VAC.
Cast heaters are available on request.
Pack includes: body & tip assembly, square coil heater and thermocouple with 1,000mm steel braid cables.

Model	d	L	d1	d2	d3	d4	d5	d6	L1	L2	L3	L4	Watts heater
All dimensions in mm.													
SGL 1636	16	35	30	4	22	5	1	25	26	10	5	38	250
SGL 1656	16	55	30	4	22	5	1	25	46	10	5	58	325
SGL 1686	16	85	30	4	22	5	1	25	76	10	5	88	470
SGL 1946	19	45	40	5	25	7	1.5	35	36	12	5	48	325
SGL 1966	19	65	40	5	25	7	1.5	35	56	12	5	68	470
SGL 1996	19	95	40	5	25	7	1.5	35	86	12	5	98	630
SGL 1960	19	58.5	54.5	5	25	7	1.5	49	41	15.5	12.5	61.5	470
SGL 2286	22	85	50	7	28	9	2	45	76	15.5	12.5	88	630
SGL 22116	22	115	50	7	28	9	2	45	106	15.5	12.5	118	630
SGL 22146	22	145	50	7	28	9	2	45	136	15.5	12.5	148	630

OPTIONS

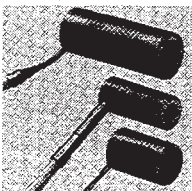

CAST HEATERS on request. To order add 'CH', eg. SGL1966CH

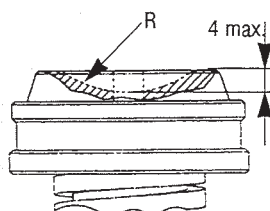

RADIUS MODIFICATION for single cavity use

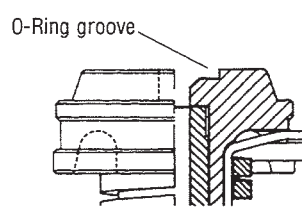

O-RING MODIFICATION for multi-cavity use

MASPRUE™ SS retrofit

- Full length BeCu core and tip
- Excellent heat profile

The MASPRUE™ SS series allows for the MASTIP™ nozzle design to be used on *modifying existing moulds or eliminating sprues* into runner systems. An electric spruebush, its central material channel allows use with most materials where absolute gate appearance is not priority.

This unique nozzle with its full length Copper Beryllium (CuBe) core *eliminates uneven heating problems*, keeping the melt temperature even throughout the nozzle.

The unique insulation area at the tip reduces the transfer of heat to the mould and cavity resulting in more efficient operation-*no gate freezing!*

The plastic material flows unrestricted through an open bore of CuBe which rapidly transfers the

heat from the square coil heater and keeps it close to the molten plastic material. This allows *precise control of temperature.*

The reliable high watt square coil heater can be connected with most standard temperature controllers that use 'J' type (FeCuNi) thermocouples.

Features:

- Adapted to existing moulds
- Single cavity or multi-cavity use

Options:

- *SSL model* – extra long, tip design – SS or SSL will suit most cavities
- *Cast heaters for longer life*
- *Teflon tip to eliminate plastic insulation for frequent colour changes*

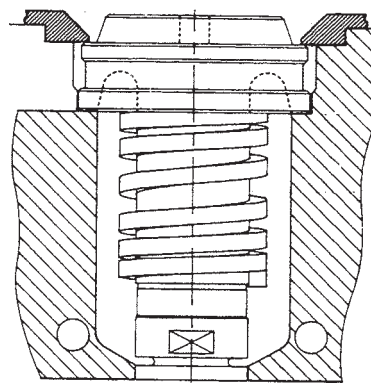
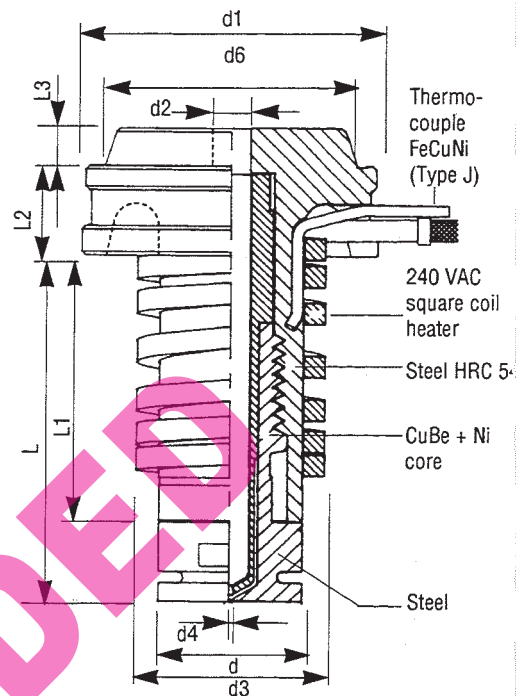

SEE FITTING INSTRUCTIONS FOR FURTHER GATE DETAILS AND SIZES

Supplied with O Ring Groove added. R 1/2 on R 3/4 will take it out. (see below)

Thermocouple – FeCuNi (Type J)
All heaters are square coil 240 VAC.
Cast heaters are available on request.
Pack includes: body & tip assembly, square coil heater and thermocouple with 1,000mm steel braid cables.

O-Ring groove

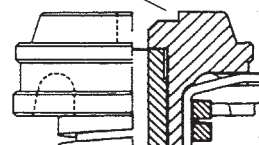

O-RING MODIFICATION for multi-cavity use

Model	d	L	d1	d2	d3	d4	d6	L1	L2	L3	Heater Watts
SS 1636	16	36	30	5	22	0.8	25	26	10	5	250
SS 1656	16	56	30	5	22	0.8	25	46	10	5	325
SS 1686	16	86	30	5	22	0.8	25	76	10	5	470
SS 1946	19	46	40	6	25	1.0	35	36	12	5	325
SS 1966	19	66	40	6	25	1.0	35	56	12	5	470
SS 1996	19	96	40	6	25	1.0	35	86	12	5	630
SS 1960	19	59.5	54.5	6	25	1.0	49	41	15.5	12.5	470
SS 2286	22	86	50	8	28	1.5	45	76	15.5	12.5	630
SS 22116	22	116	50	8	28	1.5	45	106	15.5	12.5	630
SS 22146	22	146	50	8	28	1.5	45	136	15.5	12.5	630

OPTIONS

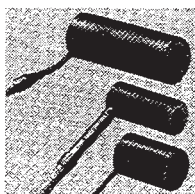

CAST HEATERS on request. To order add 'CH', eg. SS1966CH

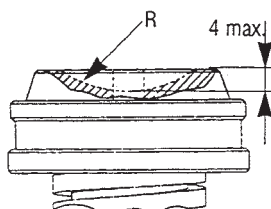

RADIUS MODIFICATION for single cavity use

MASPRUE™ SSL retrofit – extra long

- Full length BeCu core and tip
- Excellent heat profile

The MASPRUE™ SSL has a 10mm extra long tip. This expands the versatility of the MASPRUE™ nozzle series – making them adaptable to most cavities. MASPRUE™ nozzles can be used on modifying existing moulds or eliminating sprues into runner systems. An electric sprue bush, its central material channel allows use with most materials where absolute gate appearance is not priority.

This unique nozzle with its full length Copper Beryllium (CuBe) core eliminates uneven heating problems, keeping the melt temperature even throughout the nozzle.

The unique insulation area at the tip reduces transfer of heat to the mould and cavity – no gate freezing!

The plastic material flows

unrestricted through an open bore of CuBe which rapidly transfers the heat from the square coil heater and keeps it close to the molten plastic material. This allows precise control of temperature.

The reliable high watt square coil heater can be connected with most standard temperature controllers that use 'J' type (FeCuNi) thermocouples.

Features:

- Adapted to existing moulds
- Single cavity or multi-cavity use
- Nozzle easily blended into mould

Options:

- SS model – standard tip design –
- Cast heaters for longer life
- Teflon tip to eliminate plastic insulation for frequent colour changes

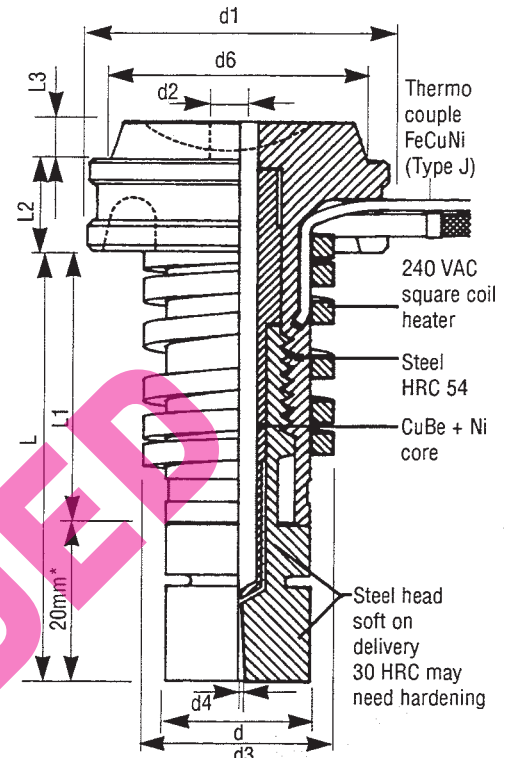

* except SSL 1960 = 28.5

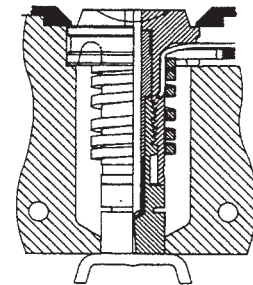

SEE FITTING INSTRUCTIONS FOR FURTHER GATE DETAILS AND SIZES

GATE DETAIL
Blending the nozzle front into the cavity surface

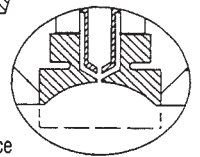

Model	d	L	d1	d2	d3	d6	L1	L2	L3	Heater Watts	d4
All dimensions in mm											
SSL 1636	16	46	30	5	22	25	26	10	5	250	0.8
SSL 1656	16	66	30	5	22	25	46	10	5	325	0.8
SSL 1686	16	96	30	5	22	25	76	10	5	470	0.8
SSL 1946	19	56	40	6	25	35	36	12	5	325	1.0
SSL 1966	19	76	40	6	25	35	56	12	5	470	1.0
SSL 1996	19	106	40	6	25	35	86	12	5	630	1.0
SSL 1960	19	69.5	54.5	6	25	49	41	15.5	12.5	470	1.0
SSL 2286	22	96	50	8	28	45	76	15.5	12.5	630	1.5
SSL 22116	22	126	50	8	28	45	106	15.5	12.5	630	1.5
SSL 22146	22	156	50	8	28	45	136	15.5	12.5	630	1.5

OPTIONS

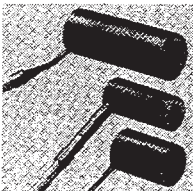

CAST HEATERS on request. To order add 'CH', eg. SSL1966CH

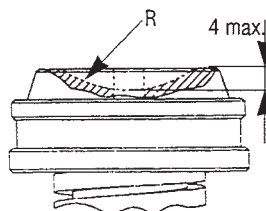

RADIUS MODIFICATION for single cavity use

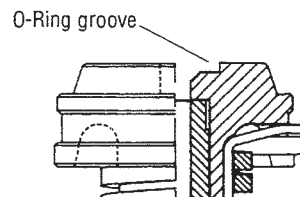

O-RING MODIFICATION for multi-cavity use

Supplied with O Ring Groove added. R 1/2 on R 3/4 will take it out. (see below)

Thermocouple – FeCuNi (Type J)
All heaters are square coil 240 VAC.
Cast heaters are available on request.
Pack includes: body & tip assembly, square coil heater and thermocouple with 1,000mm steel braid cables.

MASPOINT™ Micro Sb 12 series

- Multi-cavity/hot runner use only
- Full length BeCu core and tip
- Excellent heat profile

The MASPOINT™ 12 Series Nozzle has been used extensively for multi-cavity moulding especially in closure moulds. Recently we have added the longer Sb1275 version for use in floppy disk manufacture in Asia and moulding caps from ejection side of mould.

The full length CuBe tip press fits in from rear of nozzle which in turn makes contact directly with the manifold – metal O-Rings are recommended for reliable sealing. This gives MASPOINT™ 12 Series Nozzles a nearly perfect even temperature along their length.

The reliable high watt square coil heater can be connected with most standard temperature controllers that use 'J' type (FeCuNi) thermocouples.

Features:

- Ideal for multi-cavity cap moulds
- Suit close together applications
- Ideal for floppy disk manufacture
- Close centre to centre distances
- Uses metal O-Ring for sealing to manifold

Options:

- Teflon tip to eliminate plastic insulation for frequent colour changes
- Cast heaters for longer life

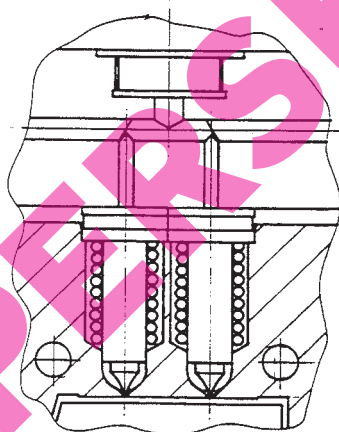
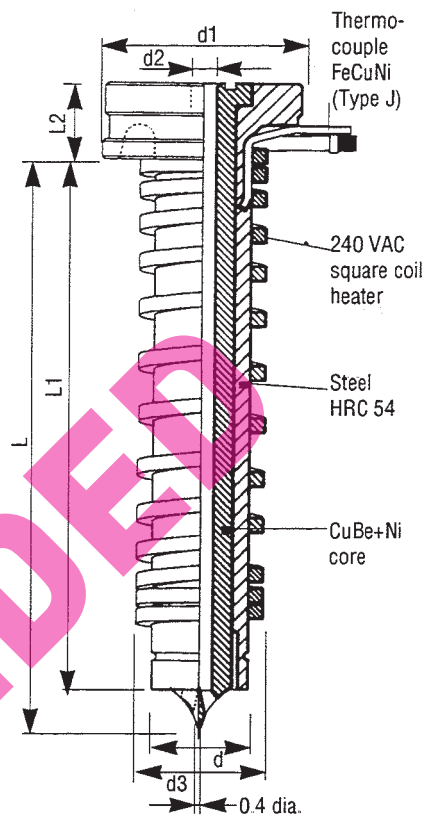

PLASTIC CASE SHOWN WITH 2 x Sb1245 NOZZLES ON MANIFOLD SYSTEM

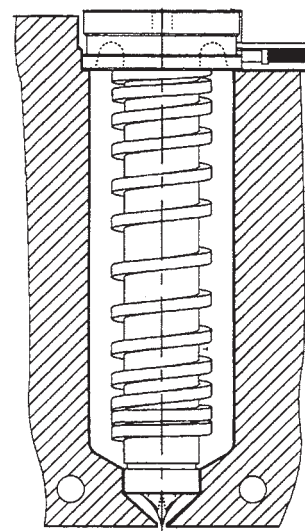

SEE FITTING INSTRUCTIONS FOR FURTHER DETAILS AND SIZES

MATERIAL GUIDE – SEE 1.1

Sb 1245	30 gm
Sb 1275	30 gm

Model	d	L	d1	Sb d2	SbH d2	d3	L1	L2	Watts heater
All dimensions in mm.									
Sb 1245	12.5	45	25	5	4	18.5	35	10	215
Sb 1275	12.5	75	25	5	4	18.5	70	12	330

Thermocouple – FeCuNi (Type J)
All heaters are square coil 240 VAC.
Cast heaters are available on request.

Pack includes: body & tip assembly, square coil heater and thermocouple with 1,000mm steel braid cables.

OPTIONS

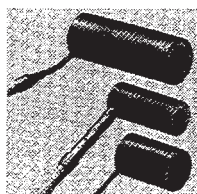

CAST HEATERS on request. To order add 'CH', eg. Sb1275CH

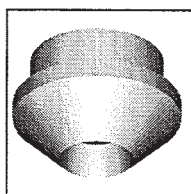

INSULATION CAP to eliminate plastic insulation. To order add 'TT', eg Sb1245TT

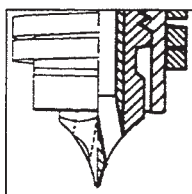

SbH tip option on request

O Ring Groove standard on these modules. Only for Multicavity use!

Large Capacity 32 series

- Full length BeCu core and tip
- Excellent heat profile
- Single or multi-cavity applications

The **LARGE CAPACITY 32 Series** is a high capacity, long series nozzle designed for injecting:

- Larger shot weights
- Engineering materials
- Parts from the ejection side of mould

The **32 Series** uses the same full length Copper Beryllium core of the other **MASTIP™** nozzles which gives it a very even heat profile – eliminating burning or freezing of plastic material.

A high capacity bore of 12.5mm diameter means a shot weight of up 3.7kg (see table) can be injected without the fear of burning caused by excessive sheer heat.

The reliable 1,000 watt 'maxi' square coil heater can be connected with most standard temperature controllers that use 'J' type (FeCuNi) thermocouples. The heater is supplied with 1,000mm metal braid leads.

Features:

- Available in 3 lengths: 150, 200 & 250
- High capacity 12.5mm bore
- Injects shot weights of up to 3.7kg
- Ideal engineering materials

Options:

- 6 Tip configurations – available in SG, SGL, Sb, SbH, SS and SSL
- Cast heaters for longer life
- Teflon tip eliminates tip insulation

OPTIONS

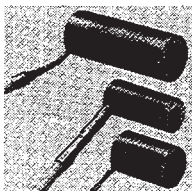

CAST HEATERS on request. To order add 'CH', eg. SS32150CH

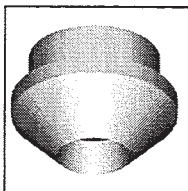

INSULATION CAP to eliminate plastic insulation. To order add 'TT', eg. Sb32150TT

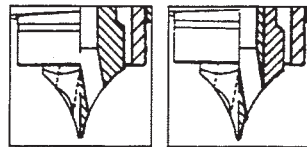

Sb tip option SbH tip option

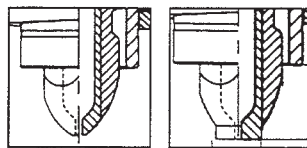

SG tip option SGL tip option

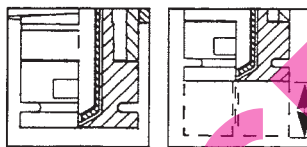

SS tip option SSL tip option

Heater-Watts 1200 All dimensions in mm

L	150, 200, 250
L4	15
L2	20
L3	15
d	32
d1	62
d2	12.5
d3	42
d4	16
d6	55
L5	17
L6	4.5
L7	15

PART NUMBERS, L=150

	150	200	250
Pin Point	Sb32150 or SbH32150	Sb32200 or SbH32200	Sb32250 or SbH32250
Open	SG32150 or SGL32150	SG32200 or SGL32200	SG32250 or SGL32250
Retro-Fit	SS32150 or SSL32100	SS32200 or SSL32200	SS32250 or SSL 32250

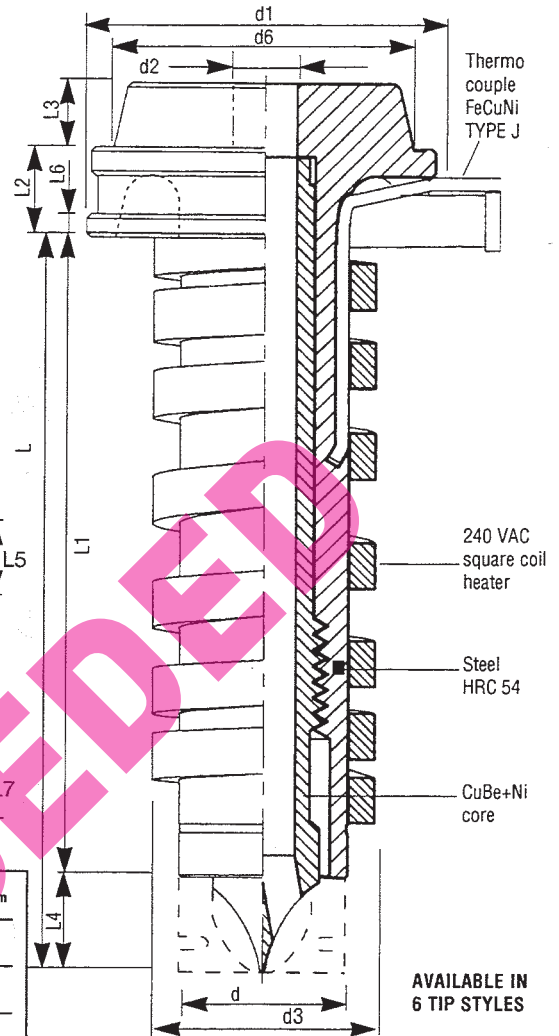

AVAILABLE IN 6 TIP STYLES

SHOT WEIGHT IN GRAMS

L =	150/200/250
Low viscosity: PP, PS, PE	2500
Medium viscosity: ABS, POM, SAN, PA, GF	2000
High viscosity: PSO, NORYL, PC, etc	1500

Note: all with 3.5mm gate diameter

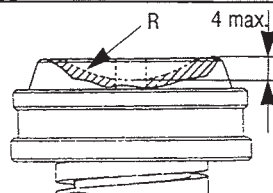

RADIUS MODIFICATION for single cavity use

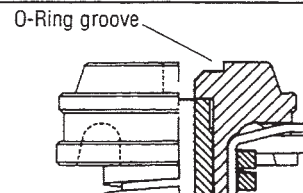

O-RING MODIFICATION for multi-cavity use

MASFLOW™ SV4017 shut off valve

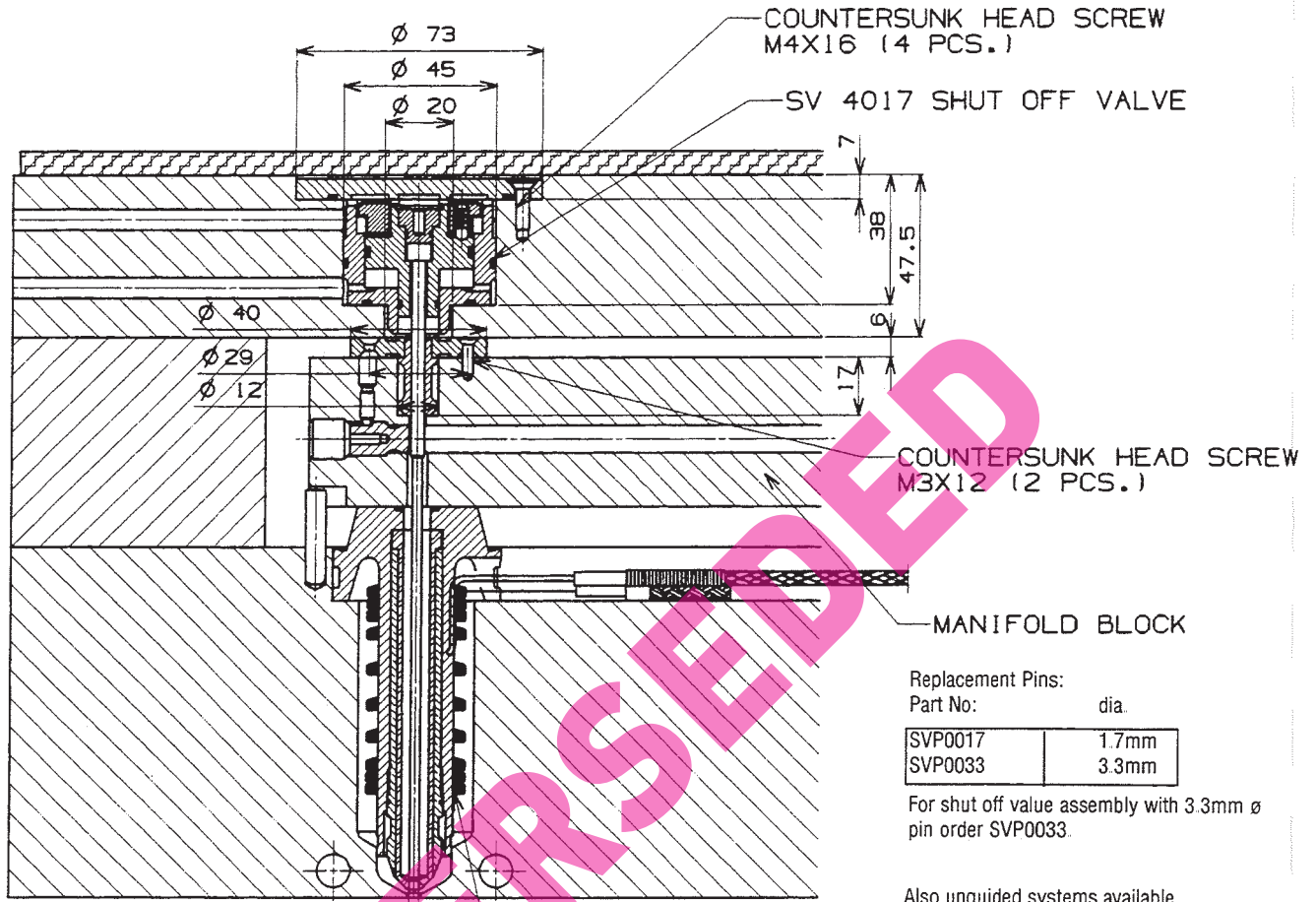

Replacement Pins:

Part No: dia.

SVP0017	1.7mm
SVP0033	3.3mm

For shut off valve assembly with 3.3mm ϕ pin order SVP0033.

Also unguided systems available

ϕ 1.7 or 3.3 REPLACEMENT PINS AVAILABLE

MASTIP NOZZLE SGV SERIES

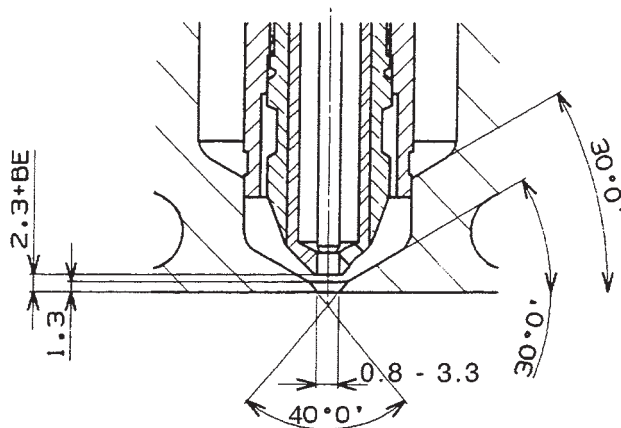
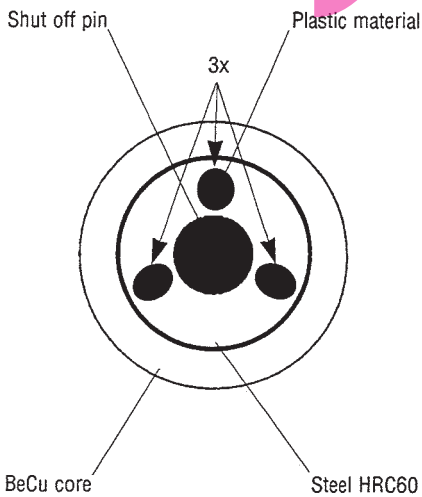

MASFLOW™ SGV valve gating nozzle

- For use with SV 4017 shut off valve
- Positive gate closure in multi-cavity moulds
- Hydraulic or pneumatic operation
- Interchangeable with similar nozzles

The MASFLOW™ SGV Series is similar in function to the MASFLOW™ SG except that it has been adapted for use with a shut off pin through the open material channel in the tip.

The full length Beryllium Copper tip contains a special replaceable hardened steel (HRC 60) sleeve inside the CuBe core that guides the pin into the gate. This makes the MASFLOW™ Series suitable for most materials including Glass Reinforced Technical Plastics requiring positive shut off.

The pin position is adjustable on the shut off valve over a working range of 4mm.

Features:

- Guided pin in nozzle tip
- Open material flow
- Uses same body and heater as SG
- Suitable most materials
- Ideal glass filled or abrasive plastics
- Suitable larger parts
- Can be used with plastic insulation or air insulation around tip by adjusting nozzle position

Options:

- Cast heaters for longer life
- Teflon tip to eliminate plastic insulation for frequent colour changes

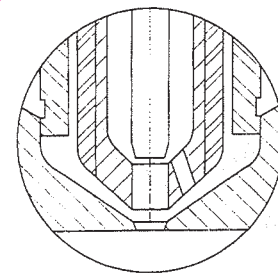
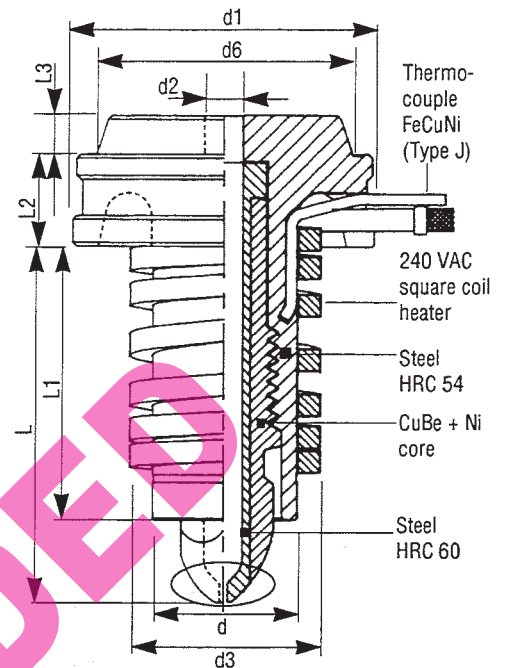

ENLARGEMENT gate detail with pin open.

END VIEW showing pin in flow channel

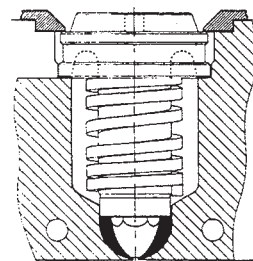
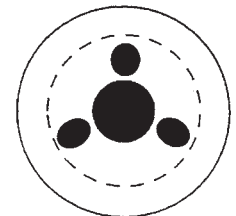

Nozzle can be adjusted forward to contact back of cavity. Eliminates plastic insulation, ideal for materials such as PMMA and Flame Retardants. OR use Teflon Bush (TT)

Model	d	L	d1	d2	d3	d6	L1	L2	L3	Watts heater
SGV 1946	19	46	40	5	25	35	36	12	5	325
SGV 1966	19	66	40	5	25	35	56	12	5	470
SGV 1996	19	96	40	5	25	35	86	12	5	630
SGV 2286	22	86	50	8	28	45	76	15.5	12.5	630
SGV 22116	22	116	50	8	28	45	106	15.5	12.5	630
SGV 22146	22	146	50	8	28	45	136	15.5	12.5	630

Supplied with O Ring Groove added. R 1/2 on R 3/4 will take it out. (see below)

Order shut off valve SV4017 separately

Thermocouple – FeCuNi (Type J)
All heaters are square coil 240 VAC.
Cast heaters are available on request.
Pack includes: body & tip assembly, square coil heater and thermocouple with 1,000mm steel braid cables.

SEE FITTING INSTRUCTIONS FOR FURTHER GATE DETAILS AND SIZES

OPTIONS

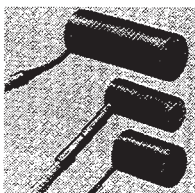

CAST HEATERS on request. To order add 'CH', eg. SG1966CH

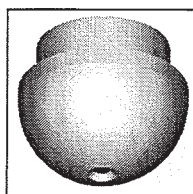

INSULATION CAP to eliminate plastic insulation. To order add 'TT', eg. SG1966TT

O-Ring groove

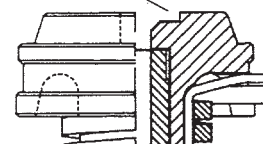

O-RING MODIFICATION for multi-cavity use

Nozzle Thermocouples

For use with AHT assemblies
Separate thermocouples
Fits all nozzles

MAST-90 L = 90

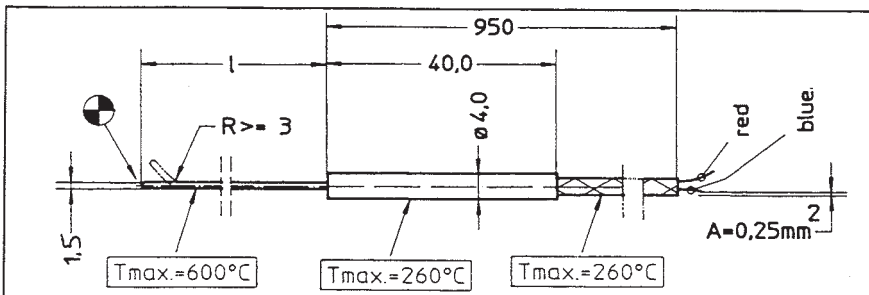

Coil heaters

High watt 3x3 square construction
240 volt, 100mm, metal leads.
When ordering with thermocouple quote 'HI' eg. 1245HI
When ordering heater only without thermocouple quote 'H' eg. 1966H
When ordering cast heater option quote 'CH' eg. 1966CH

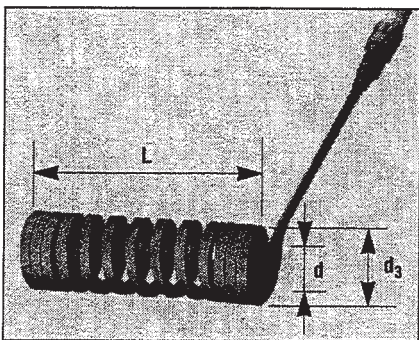

CONNECTION: 1000mm teflon insulated leads, earth and metal braided sleeving.
Unheated length: 25 + 25 mm
Voltage: 240 AC
Note: standard coil heaters ex. stock and cast heaters (CH) supplied on request

STANDARD COIL	Cast Option	L (coiled)	d (inside)	d ³	Watt	
1245	HI/H	CH	25	12.5	18.5	215
1275	HI/H	CH	65	12.5	18.5	330
1636	HI/H	CH	25	16	22	250
1656	HI/H	CH	40	16	22	325
1686	HI/H	CH	70	16	22	470
1946	HI/H	CH	35	19	25	325
1960/66	HI/H	CH	45	19	25	470
1996	HI/H	CH	80	19	25	630
2286	HI/H	CH	80	22	28	630
22116	HI/H	CH	105	22	28	630
22146	HI/H	CH	130	22	28	630
32150	H	-	135	32	41	1200
32200	H	-	180	32	41	1200
32250	H	-	230	32	41	1200

Metal 'O' Rings

For sealing nozzles to Hot Runner Systems
'Crush Fit' – replace each time the mould is assembled

O RING	d	d ₁	d ₅	d ₃
00500	9.56	12.70	12.80	8
Fits nozzles 1245, 1275, 1636, 1656, 1686, 1946, 1966, 1960, 1996, 2286, 22116, 22146				
00610	14.27	17.45	17.60	12.7
Fits nozzles 32150, 32200, 32250				

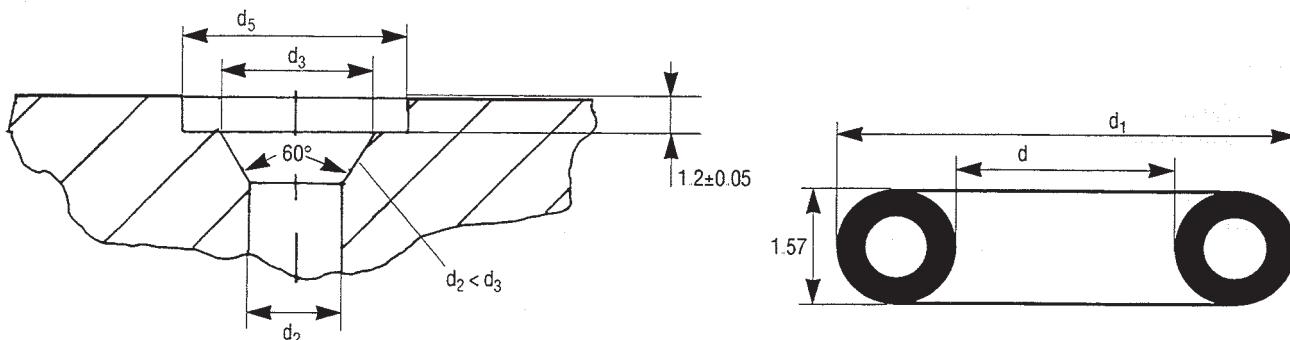

MASTIP inch sizes

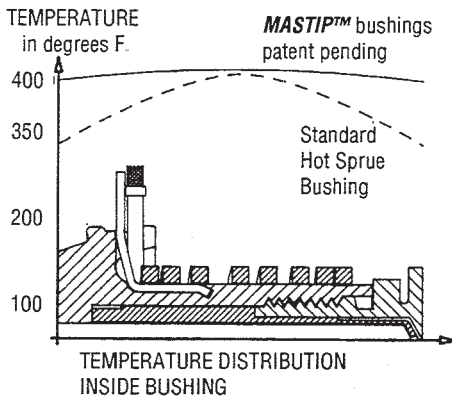

MASTIP™ 3rd generation hot sprue bushings give you more even temperature profile inside the bushing due to a unique full length Beryllium Copper core and tip which function like an internal heater—reducing the overheating of materials critical for engineering plastics.

The various tip designs are insulated from the mould, eliminating problems with heat

transfer and freezing and allowing precise control of temperature.

Our patented internal core and tip insulation area give optimal temperature control throughout the bushing—making the processing of virtually any plastic material possible.

MASTIP™ have a family of different bushings and tip styles to suit most applications.

All MASTIP™ bushings feature full length BeCu core and tip insulation for maximum performance

BUSHING SELECTION GUIDE

L=Low viscosity	PP, PS, PE
M=Medium viscosity	ABS, POM, SAN, PA6, PUR
H=High viscosity	PSO, PPE, PMMA, PC, PPS, PBT
G=Glass reinforced	GF PC, PETP, PPO, PSO, PA6.6(GF)

Model	Shot weight (oz)			
	L	M	H	G
MASPOINT™				
MSB-193375	18	9	5	3
MSB-192375	18	9	5	3
MSB-161375	4	3	2	1
MASFLOW™				
MSG-193375	21	10	7	4
MSG-192375	21	10	7	4
MSG-161375	4	3	2	1
MASPRUE™				
MS-251375	32	21	11	—
MS-251875	32	21	11	—
MS-252375	32	21	11	—
MS-252875	32	21	11	—
MS-253375	32	21	11	—
MS-253875	32	21	11	—
MS-254375	32	21	11	—

Based on gate sizes of 0.060".
These are recommendations only.
Conversion: 28.3gms = 102

MASPOINT™

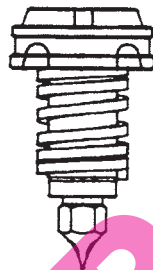

Pin Point

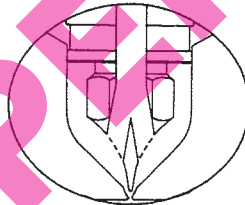

Cosmetic Gate Finish

MASFLOW™



Open Flow

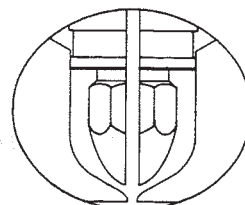

Large parts and Engineering Materials

MASPRUE™

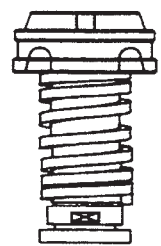

Retro Fit

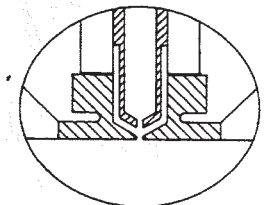

Replaces Cold Sprues

NOTE: MASPOINT and MASFLOW™ tips are interchangeable in the same bushing and mold although some gate fitting changes may be required.

MASTIP™ ADVANTAGES

The new MASTIP™ series advanced design results in:

- Higher moulding efficiency.
- Less temperature variation.
- Reduced stress on plastic materials.
- Faster start up of moulds.
- Eliminates gate material 'freezing'.
- Minimises heat transfer to mould.
- Makes better parts—faster.

MASTIP™ has been making these types of bushings for over twelve years. Thousands are in use around the world under various brand names.

Continued development of our MASTIP™ bushings has resulted in the current third generation patent pending series.

MASPOINT™ MSB

- Full length BeCu core and tip
- Excellent heat profile
- 2 Interchangeable tip styles – standard and hard tip

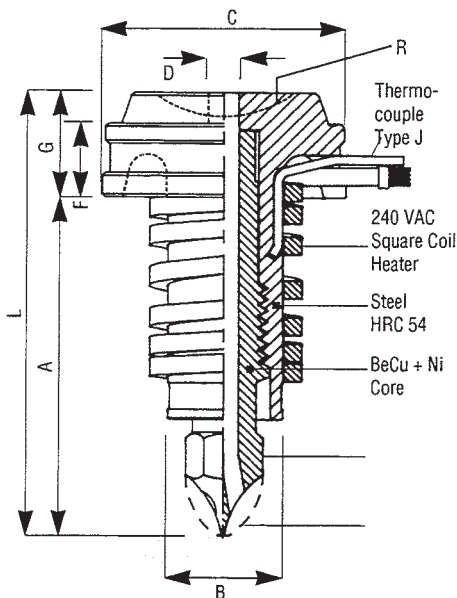

MASPOINT™ MSB (shown)
MSBH HRC60 steel tip version available.

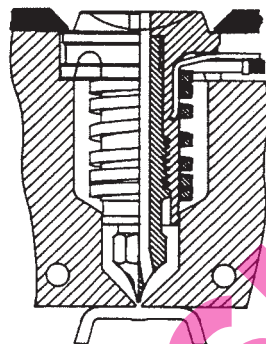

SEE FITTING INSTRUCTIONS FOR FURTHER GATE DETAILS AND SIZES

This latest, third generation design features a hardened nickel plated full length Beryllium Copper (BeCu) core. This gives the bushing a better heat profile which is essential to avoid burning plastic material.

The **MASPOINT™ (MSB)** bushing is an advanced hot sprue bushing for *pinpoint gating directly into cavities* or eliminating sprues feeding into runner systems.

Most materials can be moulded with this bushing due to its extremely even heat profile through the bushing.

The gate area stays 'live' due to the incredible heat transfer of the full length BeCu core and tip insulation. Special tips are available for *frequent colour changes*.

The reliable high watt coil heater can be connected with most standard temperature controllers that utilise the 'J Type' thermocouple. Optional cast heaters for longer life are available.

The gate cosmetics can be easily adjusted to suit each application.

Optional hard tip versions are available for *glass filled materials*.

CAT. No.	L	A	B	C	R	D	F	G	Watts
MASPOINT™ assemblies include body, tip, square coil heater and thermocouple									
MSB-193375	4.437	3.375	.750	2.156	1/2 & 3/4	.250	.562	1.062	610
MSB-192375	3.437	2.375	.750	2.156	1/2 & 3/4	.250	.562	1.062	470
MSB-161375	2.000	1.375	.625	1.500	1/2 & 3/4	.156	.325	.625	250

All heaters are square coil 240 VAC and are supplied with 40" steel braided leads. 120 VAC heaters are available on special order.

MASPOINT™ MSBH - hard steel tip - pinpoint gating

The MSBH has a hard steel (60)HRC tip which is interchangeable with the standard MSB nozzle range – *it fits exactly in the MSB nozzle body*.

The MSH Series expands the versatility of the MSB nozzles to

include abrasive and glass reinforced materials. Its unique insulated tip area can be positioned very close to the product inside the gate area resulting in *minimum mark on plastic parts and replacing sprues feeding into runner systems*.

OPTIONS

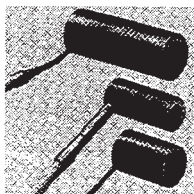

CAST HEATERS on request. To order add 'CH', eg. SbH1966CH

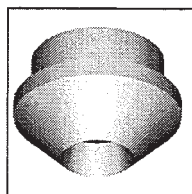

INSULATION CAP to eliminate plastic insulation. To order add 'TT', eg SbH1966TT

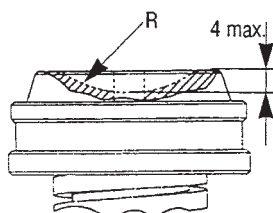

RADIUS MODIFICATION for single cavity use

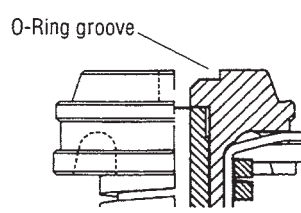

O-RING MODIFICATION for multi-cavity use

MASFLOW™ MSG

- Full length BeCu core and tip
- Excellent heat profile
- Interchangeable with similar bushings

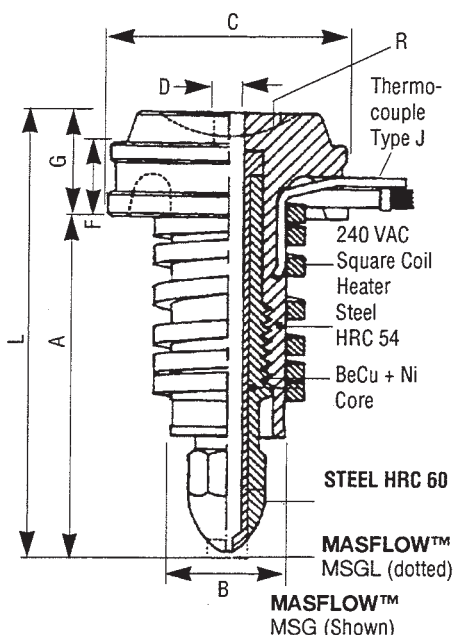

SEE FITTING INSTRUCTIONS FOR FURTHER GATE DETAILS AND SIZES

This latest, third generation design features a hardened nickel plated full length Beryllium Copper (BeCu) core. This gives the bushing a better heat profile which is essential to avoid burning plastic material.

The MASFLOW™ (MSG) bushing is an open flow version which differs from the MASPOINT™ only in the tip design. The tip is interchangeable in the MASPOINT™ bushing body.

The open flow path makes it ideal for larger parts, engineering materials, and heat sensitive plastics.

Most materials can be moulded with this bushing due to its extremely even heat profile through the bushing.

The reliable high watt coil heater can be connected with most standard temperature controllers that utilise the 'J Type' thermocouple. Optional cast heaters for longer life are available.

A big advantage of the MASFLOW™ is its replacable steel sleeve inside the BeCu core—ideal for abrasive plastics.

The MASFLOW™ can be used, either with the normal plastic insulation around the tip (as shown), or by bringing the bushing forward until it is just touching the back of the cavity (shown by arrow), leaving only an air gap—ideal for technical materials such as PMMA and flame retardant materials.

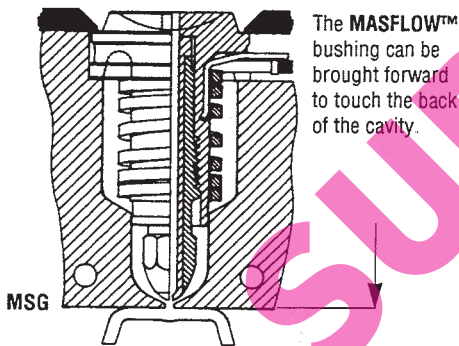

CAT. No.	L	A	B	C	R	D	F	G	Watts
MASFLOW™ assemblies include body, tip, square coil heater and thermocouple									
MSG-193375	4.437	3.375	.750	2.156	1/2 & 3/4	.250	.562	1.062	610
MSG-192375	3.437	2.375	.750	2.156	1/2 & 3/4	.250	.562	1.062	470
MSG-161375	2.000	1.375	.625	1.500	1/2 & 3/4	.156	.325	.625	250
All heaters are square coil 240 VAC and are supplied with 40" steel braided leads. 120 VAC heaters are available on special order.									

MASFLOW™ MSGL - No plastic insulation at tip

The MASFLOW™ MSGL Series is designed for technical plastics, difficult materials including those that are glass fibre reinforced. The extra hard (HRC 60) steel inner tip protrudes through to the cavity face, eliminating the plastic

insulation around the tip usual with the MASFLOW™ MSG.

An air gap exists around the tip.

The MASFLOW™ MSGL exploits the same clean open material channel through one hole in the tip.

OPTIONS

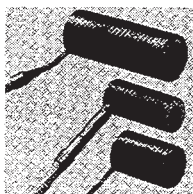

CAST HEATERS on request. To order add 'CH', eg. SbH1966CH

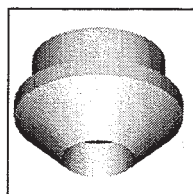

INSULATION CAP to eliminate plastic insulation. To order add 'TT', eg. SbH1966TT

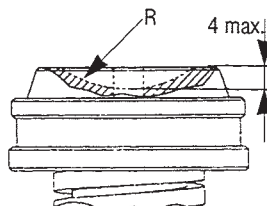

RADIUS MODIFICATION for single cavity use

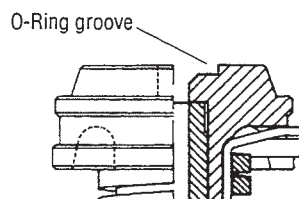

O-RING MODIFICATION for multi-cavity use

MASPOINT™ (shown)

MASFLOW™ (dotted)

MASPRUE™ MS

Patent Pending

- Full length BeCu core and tip
- Excellent heat profile
- Interchangeable with most 1" bushings

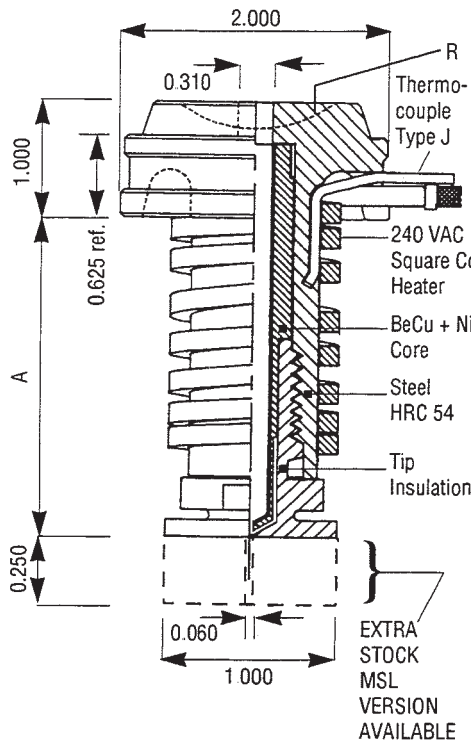

This unique bushing with its full length Beryllium Copper (BeCu) core *eliminates uneven heating problems*, keeping the melt temperature even throughout the bushing.

The unique insulation area at the tip reduces the transfer of heat to the mould and cavity resulting in more efficient operation—*no gate freezing!*

The plastic material flows unrestricted through an open bore of BeCu which rapidly transfers the

heat from the square coil heater and keeps it close to the molten plastic material. This allows *precise control of temperature*.

Optional cast heaters for longer life are available (see price list).

The bushing can be modified to suit most cavities with the .250 extra long MSL version.

Each bushing has a 'J Type' thermocouple which can be coupled to any standard temperature controller.

CAT. No	A	Watts	R
MS-251375	1.375	325	1/2 & 3/4
MS-251875	1.875	470	1/2 & 3/4
MS-252375	2.375	610	1/2 & 3/4
MS-252875	2.875	610	1/2 & 3/4
MS-253375	3.375	630	1/2 & 3/4
MS-253875	3.875	630	1/2 & 3/4
MS-254375	4.375	630	1/2 & 3/4

All heaters are square coil 240 VAC. 120 VAC heaters are available on special order.

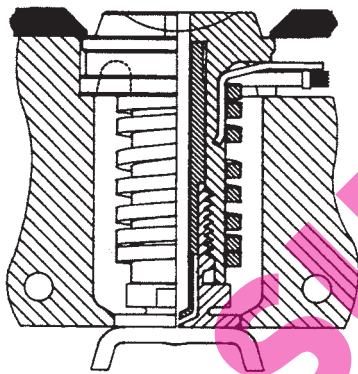

SEE FITTING INSTRUCTIONS FOR FURTHER GATE DETAILS AND SIZES

MASPRUE™ bushings are manufactured to standard sprue bush sizes and can be easily used to:

- replace existing cold sprues.
- replace inefficient hot bushings.

• feed into runner systems.

Most materials can be processed with the MASPRUE™. Abrasive materials may require a specially hardened internal core version.

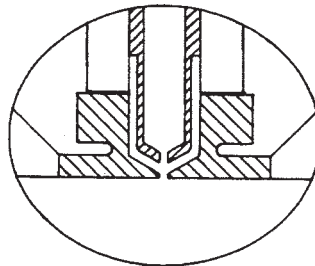

STANDARD MASPRUE MS

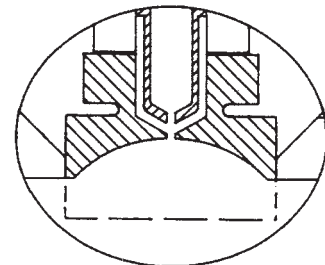

MASPRUE MODIFICATION MSL
Blending the bushing front into the cavity surface

OPTIONS

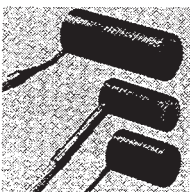

CAST HEATERS on request. To order add 'CH', eg. SbH1966CH

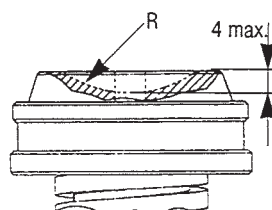

RADIUS MODIFICATION for single cavity use

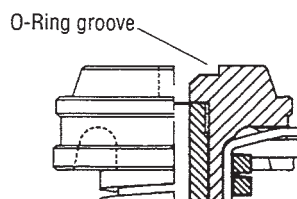

O-RING MODIFICATION for multi-cavity use

MASFLOW™ SV4017/SV4033/SV4060 shut off valve

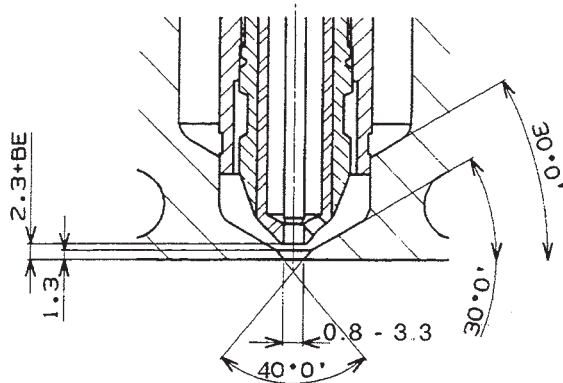
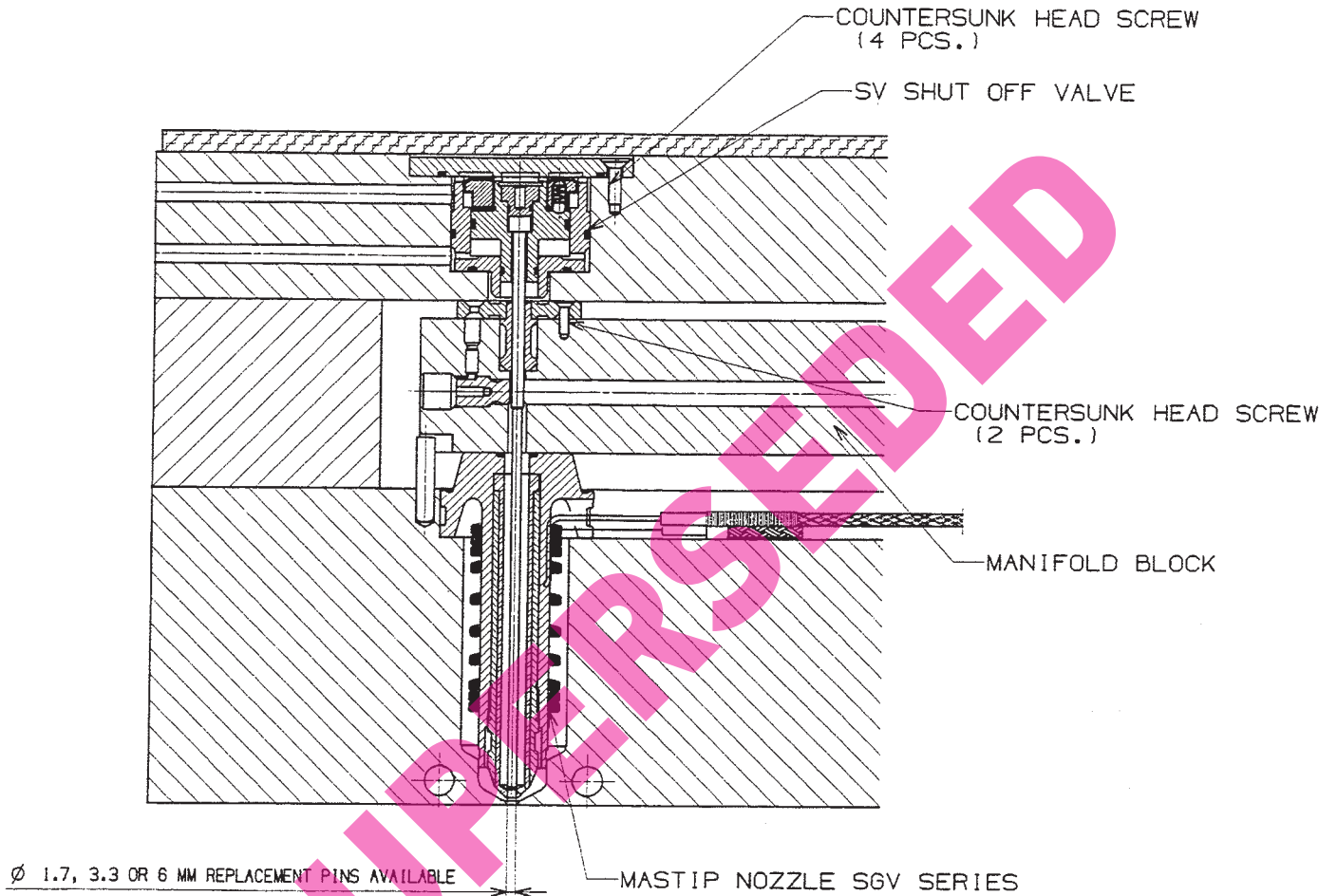

MASFLOW™ SV4017/SV4033 shut off valve - Machining detail

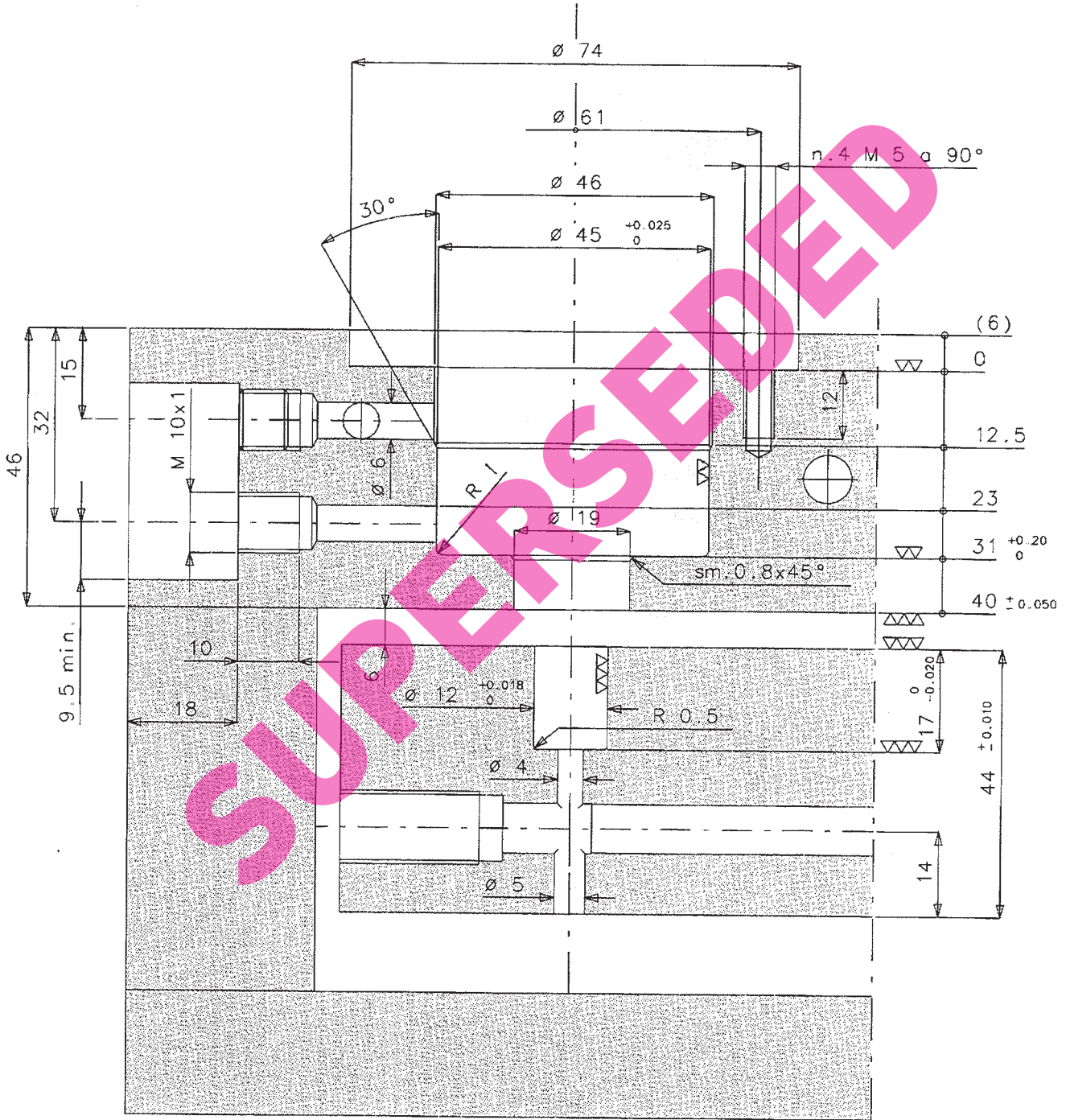

MASFLOW™ SV4060 shut off valve - Machining detail

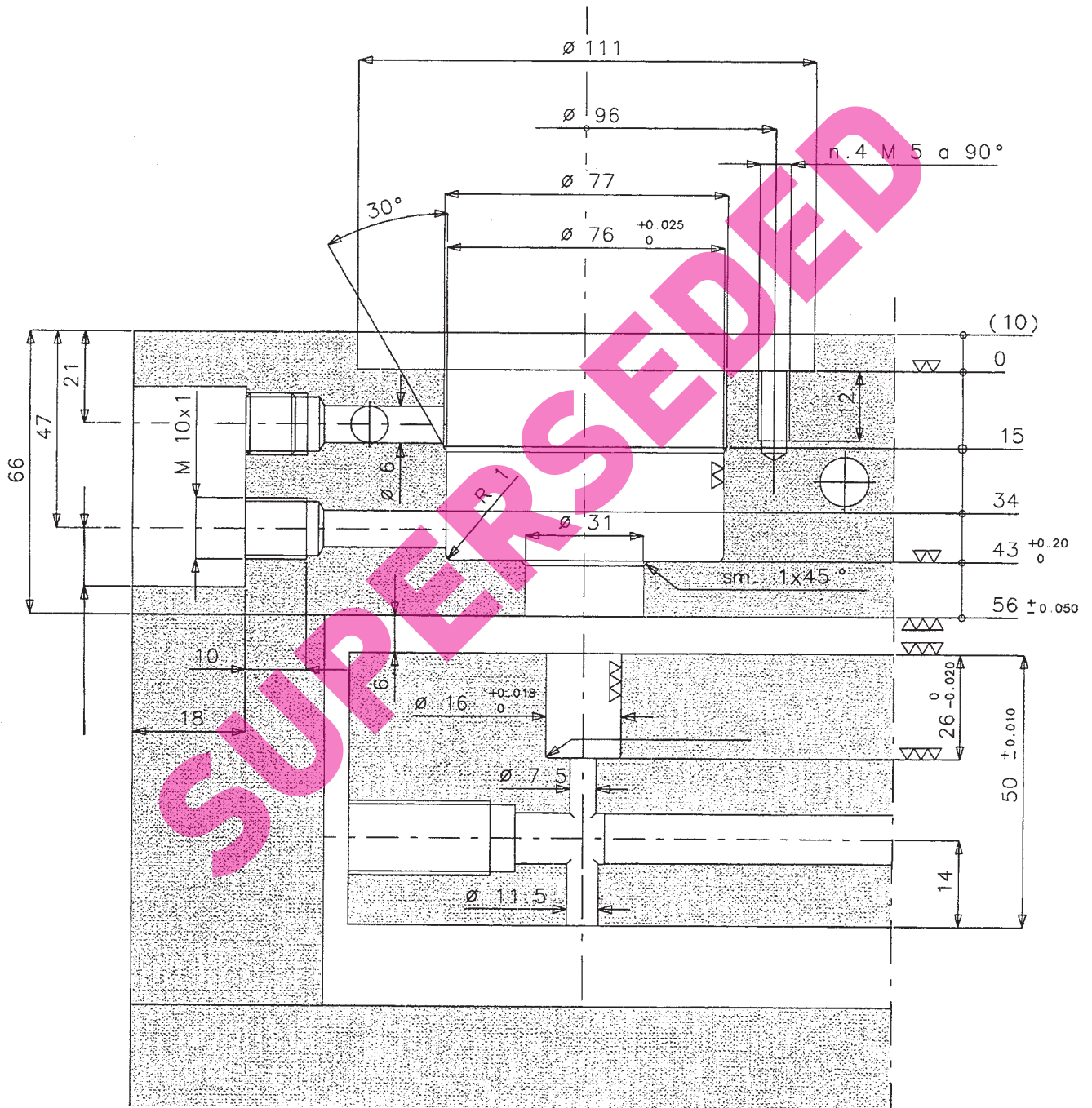

MASFLOW™ SV4060

SVH4060

Mat. W. Nr.: 1.2312 - 120 Kg/mm²

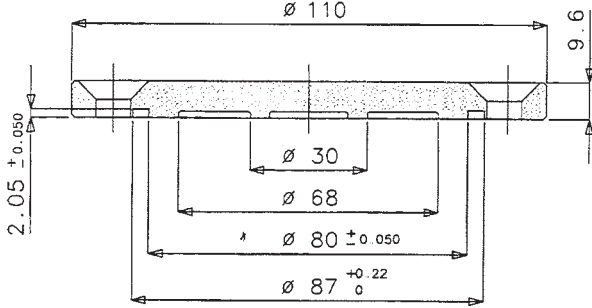

SVT4060

Mat. Tiarene - 80 Kg/mm²

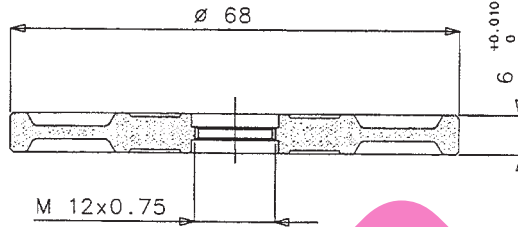

SVP0060

Mat. W. Nr.: 1.3343

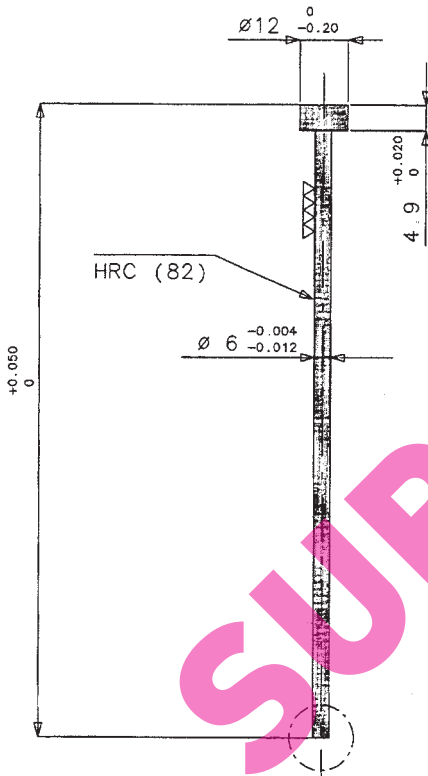

SVG4060

Mat. W. Nr.: 1.2343 HRC (50-52)

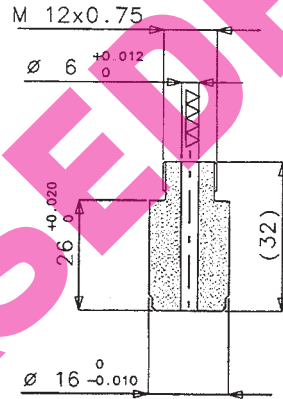

MASTIP™ VALVE GATING NOZZLE

	d2	L
SGV25	10	as required
SGV25	12	as required

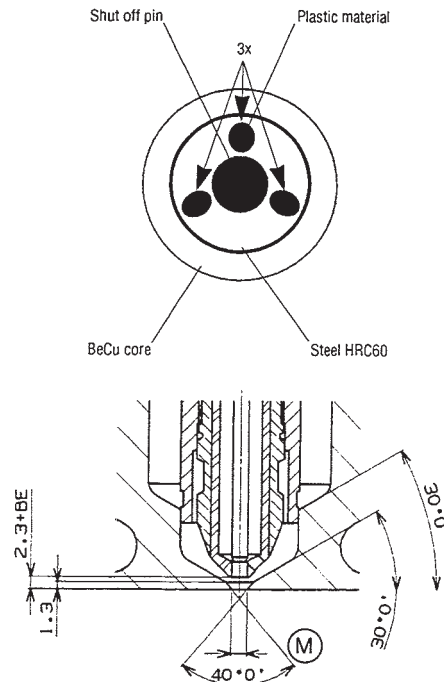
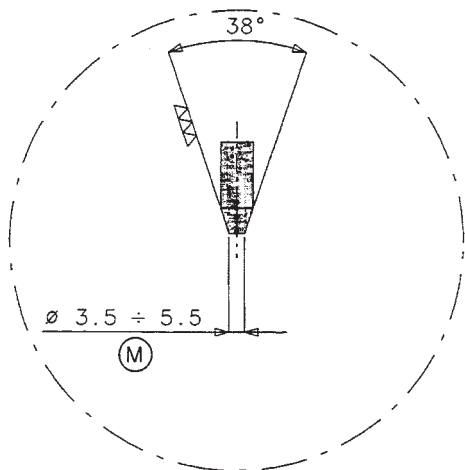

MASFLOW™ SV4017/4033

SVH4130

Cylinder Hold Down Plate

Mat. W. Nr.: 1.2312 - 120 Kg/mm²

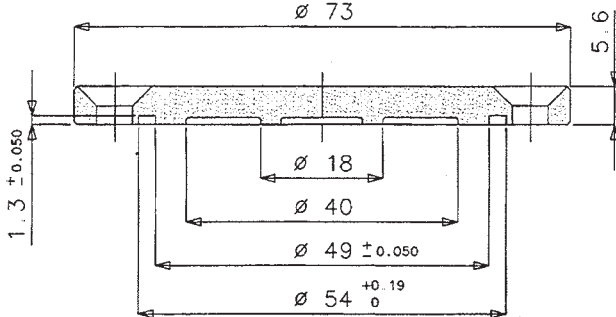

SVT4130

Material Titanium

Mat. Titane - 80 Kg/mm²

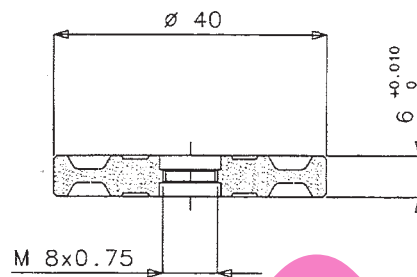

Shut off Pin, Titanium Nitride Coated

Mat. W. Nr.: 1.3343

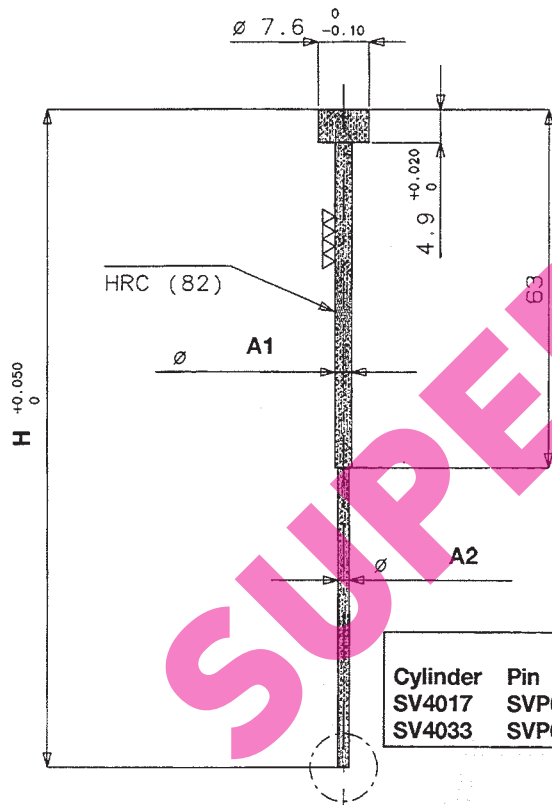

Hardened Steel Pin Guide Bush

Mat. W. Nr.: 1.2343 HRC (50-52)

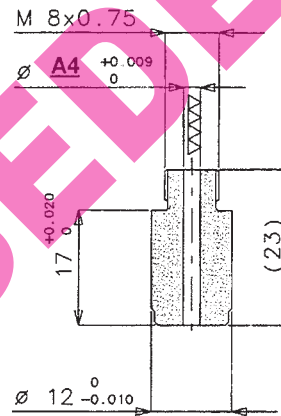

A4
SVG4017 2.5
SVG4033 3.5

MASTIP™ VALVE GATING NOZZLE

	d2	L
SGV 1946/66/96	6	46,66,96
SGV2286/116/146	8	86,116,146

PIN DETAILS					
Cylinder	Pin	A1	A2	A3	H
SV4017	SVP0017	2.5	1.7	0.8 - 1.3	186.5
SV4033	SVP0033	3.5	3.3	1.6 - 2.5	252.2

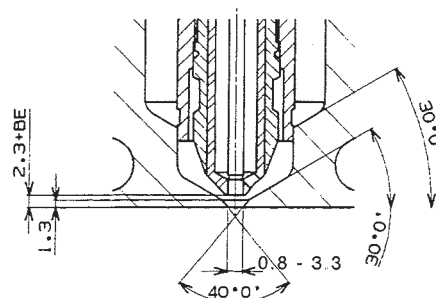
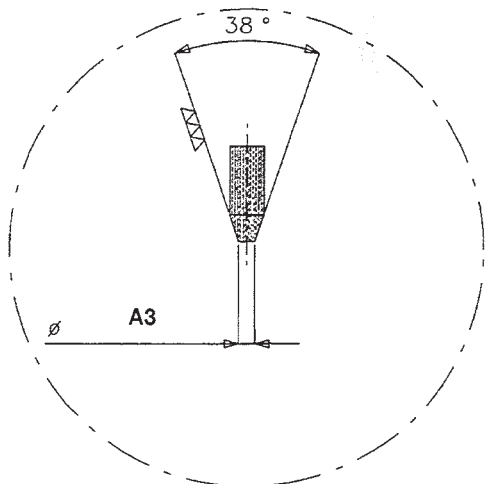
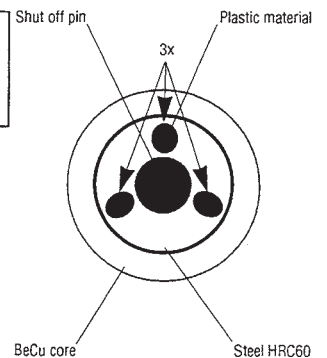

MASFLOW™ SV4060

(A) Installation - incorporating airway inside backplate

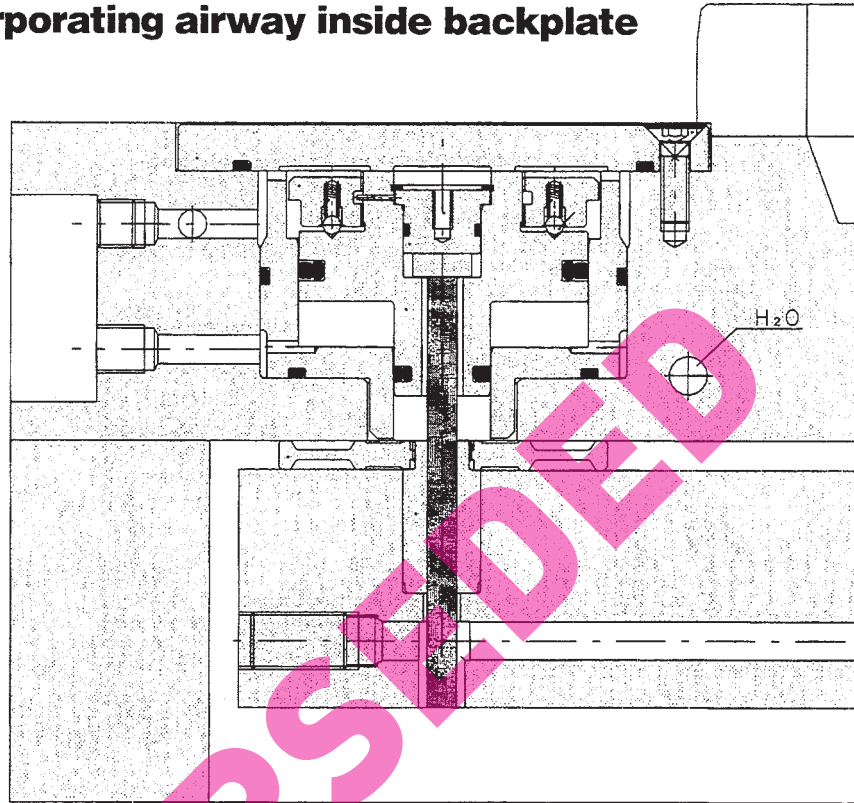

(B) Installation - with top outside airway

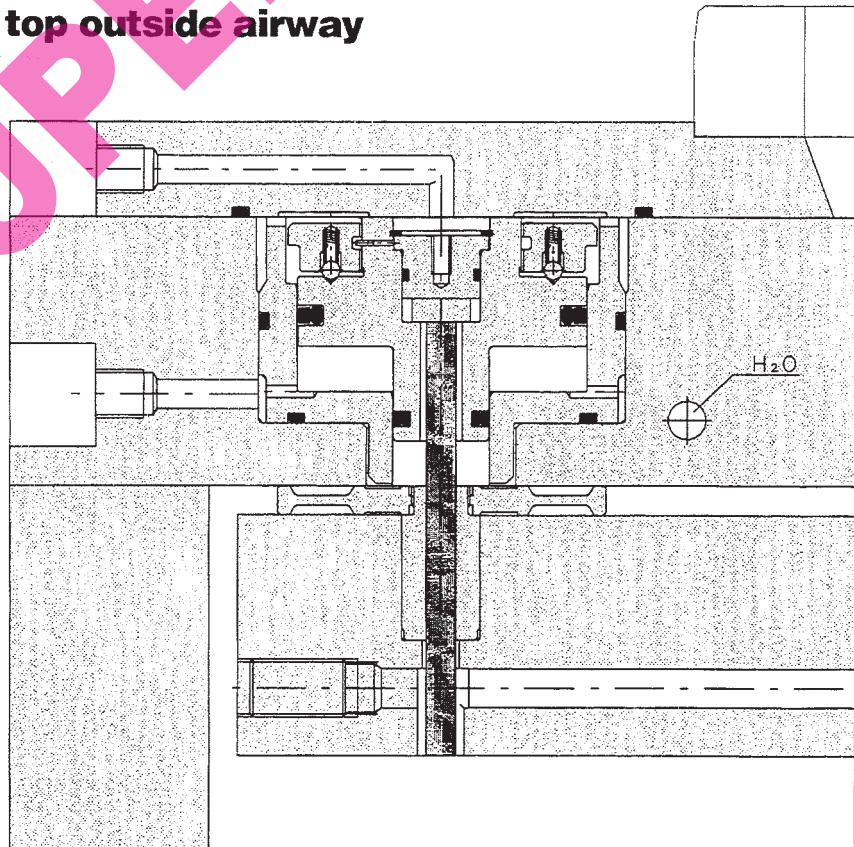

MASFLOW™ SV4017/4033

(A) Installation - incorporating airway inside backplate

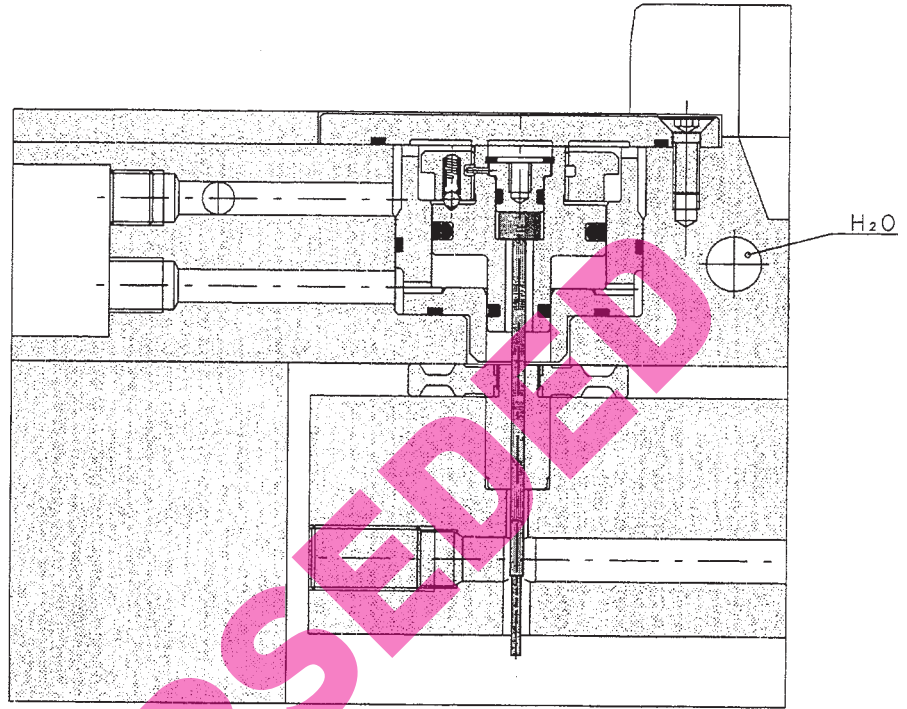

(B) Installation - with top outside airway

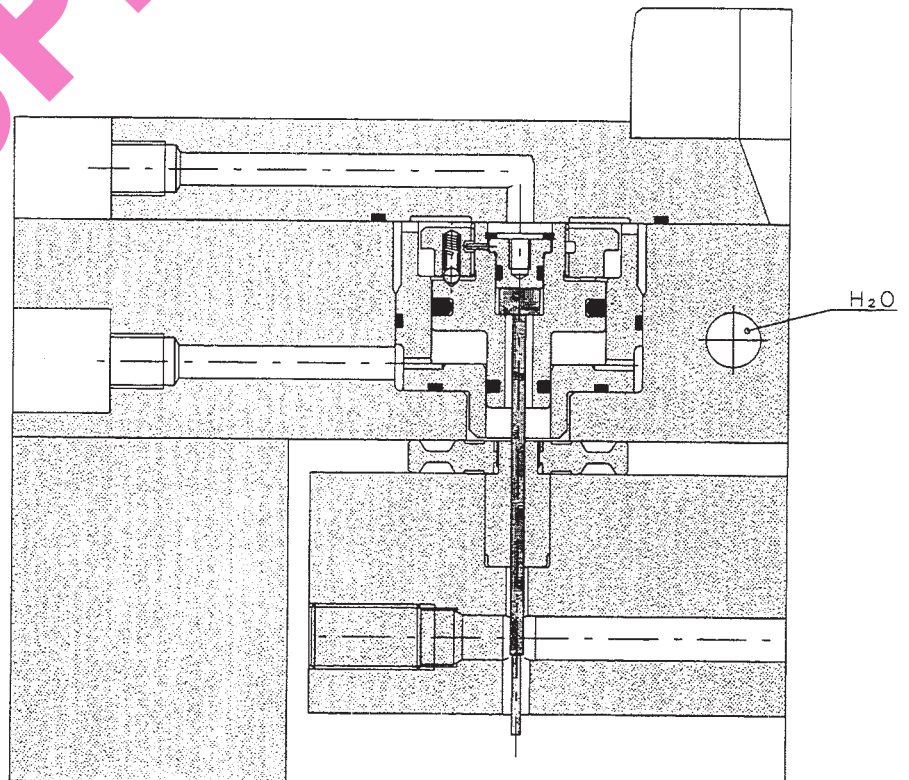

SUPERSEDED